



# MMP SA-715A

## SERVO AMPLIFIER

Description	Power Range
Peak Current	15 A
Continuous Current	7.5 A
Supply Voltage	20 - 80 VDC

The MMP SA-715A servo amplifier is designed to drive brushed or brushless type DC motors at a high switching frequency. A single red/green LED indicates operating status. The drive is fully protected against over-voltage, under-voltage, over-current, over-heating and short-circuits across motor, ground and power leads. Furthermore, the drive can interface with digital controllers or be used stand-alone, and requires only a single unregulated DC power supply. Loop gain, current limit, input gain and offset can be adjusted using 14-turn potentiometers. The offset adjusting potentiometer can also be used as an on-board input signal for testing purposes. This drive can use quadrature encoder inputs for velocity control.



### Features

- ↳ Four Quadrant Regenerative Operation
- ↳ DIP Switch Selectable Modes
- ↳ DIP Switch Configurable Loop Tuning
- ↳ Selectable Inhibit Logic
- ↳ Adjustable Current Limits
- ↳ High Switching Frequency
- ↳ Differential Input Command
- ↳ Digital Fault Output Monitor
- ↳ On-Board Test Potentiometer
- ↳ Offset Adjustment Potentiometer
- ↳ Adjustable Input Gain
- ↳ Selectable 120/60 Hall Commutation Phasing
- ↳ Encoder Velocity Mode
- ↳ Velocity Monitor Output
- ↳ Current Monitor Output
- ↳ Drive Status LED

#### MODES OF OPERATION

- ↳ Current
- ↳ Encoder Velocity
- ↳ Duty Cycle (Open Loop)

#### COMMAND SOURCE

- ↳ ±10 V Analog

#### FEEDBACK SUPPORTED

- ↳ Hall Sensors
- ↳ Incremental Encoder

#### MOTORS SUPPORTED

- ↳ Three Phase (Brushless)
- ↳ Single Phase (Brushed, Voice Coil, Inductive Load)

#### COMPLIANCES & AGENCY APPROVALS

- ↳ UL
- ↳ cUL
- ↳ CE Class A (LVD)
- ↳ CE Class A (EMC)
- ↳ RoHS II

**BLOCK DIAGRAM**

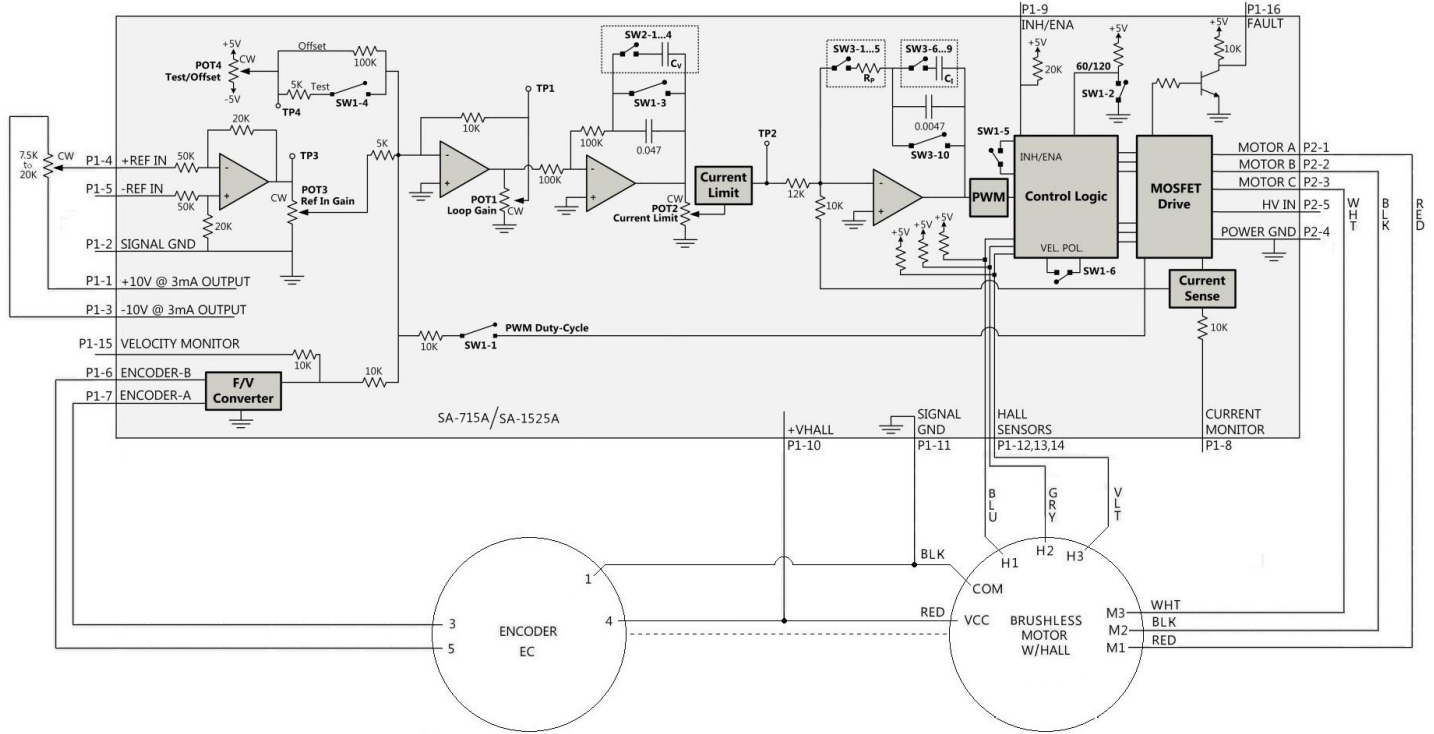

Mode Selection Table		
Mode	SW1-1	SW1-3
Current Mode	OFF	ON
Duty Cycle Mode	ON	OFF
Encoder Velocity Mode	OFF	OFF

LED Behavior	
Color	Function
Green	Normal Operation
Red	Fault Condition

Default mode is Duty Cycle Mode, with maximum current settings.  
 Recommended potentiometer setting for Duty Cycle Mode is:  
 Pot 1 = Full CCW, Pot 2 = Full CW, Pot 3 = Full CW.

Note that the above diagram is for a brushless motor with Hall effects and with or without an encoder. If you have purchased other hardware to run with the amplifier then the above wiring scheme does not apply. Contact MMP for more details.

**Information on Approvals and Compliances**

	US and Canadian safety compliance with UL 508c, the industrial standard for power conversion electronics. UL registered under file number E140173. Note that machine components compliant with UL are considered UL registered as opposed to UL listed as would be the case for commercial products.
	Compliant with European EMC Directive 2004/108/EC on Electromagnetic Compatibility (specifically EN 61000-6-4:2007 for Emissions, Class A and EN 61000-6-2:2005 for Immunity, Performance Criteria A). LVD requirements of Directive 2006/95/EC (specifically, EN 60204-1:2004, a Low Voltage Directive to protect users from electrical shock).
	The RoHS II Directive 2011/65/EU restricts the use of certain substances including lead, mercury, cadmium, hexavalent chromium and halogenated flame retardants PBB and PBDE in electronic equipment.

**SPECIFICATIONS**

Power Specifications		
Description	Units	Value
DC Supply Voltage Range	VDC	20 - 80
DC Bus Over Voltage Limit	VDC	88
DC Bus Under Voltage Limit	VDC	15
Maximum Peak Output Current <sup>1</sup>	A	15
Maximum Continuous Output Current	A	7.5
Maximum Continuous Output Power at Continuous Current	W	570
Maximum Power Dissipation at Continuous Current	W	30
Minimum Load Inductance (Line-To-Line) <sup>2</sup>	μH	200
Internal Bus Capacitance	μF	TBD
Low Voltage Supply Outputs	-	±10 VDC (3 mA), +6 VDC (30 mA)
Switching Frequency	kHz	22
Control Specifications		
Description	Units	Value
Command Sources	-	±10 V Analog
Feedback Supported	-	Hall Sensors, Incremental Encoder
Commutation Methods	-	Trapezoidal
Modes of Operation	-	Current, Encoder Velocity, Duty Cycle (Open Loop)
Motors Supported	-	Three Phase (Brushless), Single Phase (Brushed, Voice Coil, Inductive Load)
Hardware Protection	-	Over-Current, Over-Temperature, Over-Voltage, Under-Voltage, Short-Circuit (Phase-Phase & Phase-Ground)
Primary I/O Logic Level	-	5V TTL
Mechanical Specifications		
Description	Units	Value
Agency Approvals	-	CE Class A (EMC), CE Class A (LVD), cUL, RoHS II, UL
Size (H x W x D)	mm (in)	129.3 x 75.8 x 25.1 (5.09 x 2.98 x 0.99)
Weight	g (oz)	249.5 (8.8)
Heatsink (Base) Temperature Range <sup>3</sup>	°C (°F)	0 - 65 (32 - 149)
Storage Temperature Range	°C (°F)	-40 - 85 (-40 - 185)
Form Factor	-	Panel Mount
P1 Connector	-	16-pin, 2.54 mm spaced, friction lock header
P2 Connector	-	5-port, 5.08 mm spaced, quick disconnect terminal

**Notes**

1. Maximum duration of peak current is ~2 seconds. Peak RMS value must not exceed continuous current rating of the drive.
2. Lower inductance is acceptable for bus voltages well below maximum. Use external inductance to meet requirements.
3. Additional cooling and/or heatsink may be required to achieve rated performance.

**PIN FUNCTIONS**

P1 - Signal Connector			
Pin	Name	Description / Notes	I/O
1	+10V 3mA OUT	±10 V @ 3 mA low power supply for customer use. Short circuit protected. Reference ground common with signal ground.	O
2	SIGNAL GND		GND
3	-10V 3mA OUT		O
4	+REF IN	Differential Reference Input (±10 V Operating Range, ±15 V Maximum Input)	I
5	-REF IN		I
6	ENCODER-B IN	Single-ended encoder channel B input. +5 V logiclevel.	I
7	ENCODER-A IN	Single-ended encoder channel A input. +5 V logiclevel.	I
8	CURRENT MONITOR	Current Monitor. Analog output signal proportional to the actual current output. Scaling is 2.0 A/V. Measure relative to signal ground.	O
9	INHIBIT / ENABLE	TTL level (+5 V) inhibit/enable input. Pull to ground to inhibit drive (SW1-5 ON). Pull to ground to enable drive (SW1-5 OFF). Inhibit turns off all power devices.	I
10	+V HALL 30mA OUT	Low Power Supply For Hall Sensors (+6 V @ 30 mA). Referenced to signal ground. Short circuit protected.	O
11	GND	Signal Ground	GND
12	HALL 1	Single-ended Hall/Commutation Sensor Inputs (+5 V logiclevel). Leave open for brushed motors.	I
13	HALL 2		I
14	HALL 3		I
15	VEL MONITOR OUT	Velocity Monitor. Analog output proportional to motor speed. In Encoder Velocity mode, output is proportional to the encoder line frequency. Encoder Velocity scaling is 22 kHz/V.	O
16	FAULT OUT	TTL level (+5 V) output becomes high when power devices are disabled due to at least one of the following conditions: inhibit, invalid Hall state, output short circuit, over voltage, over temperature, power-up reset.	O

P2 - Power Connector			
Pin	Name	Description / Notes	I/O
1	A	Motor Phase A	O
2	B	Motor Phase B	O
3	C	Motor Phase C	O
4	POWER GND	Power Ground (Common With Signal Ground)	PGND
5	HIGH VOLTAGE	DC Power Input	I

## HARDWARE SETTINGS

### Configuration Switch Functions

SW1	Description	Setting	
		On	Off
1	Duty Cycle mode selector. Activates internal PWM feedback.	Duty Cycle mode	Other modes
2	60/120 degree commutation phasing setting	120 degrees	60 degrees
3	Outer loop integration. Activates or deactivates integration. ON, by default, for current mode and OFF for other modes.	Inactive	Active
4	Test/Offset. Switches the function of the Test/Offset pot between an on-board command input for testing or a command offset adjustment. OFF by default.	Test	Offset
5	Inhibit logic. Sets the logic level of inhibit pins.	Drive Inhibit is active low	Drive Inhibit is active high
6	Velocity feedback polarity. Changes the polarity of the internal feedback signal and the velocity monitor output signal. Inversion of the feedback polarity may be required to prevent a motor run-away condition. ON by default.	Standard	Inverted

### Mode Selection Table

	SW1	SW3	Encoder
CURRENT	OFF	ON	Not Connected
DUTY CYCLE	ON	OFF	Not Connected
ENCODER VELOCITY*	OFF	OFF	Connected

\*Note: Use SW1-6 to change the feedback polarity if necessary. This may be required to prevent a run-away condition.

### Potentiometer Functions

Potentiometer	Description	Turning CW
1	Loop gain adjustment for duty cycle / velocity modes. Turn this pot fully CCW in current mode.	Increases gain
2	Current limit. It adjusts both the continuous and peak current limit while maintaining their ratio.	Increases limit
3	Reference gain. Adjusts the ratio between input signal and output variables (voltage, current, or velocity).	Increases gain
4	Offset / Test. Used to adjust any imbalance in the input signal or in the amplifier. Can also be used as an on-board signal source for testing purposes.	Adjusts offset in negative direction

Note: Potentiometers are approximately linear and have 12 active turns with 1 inactive turn on each end. Test points are provided on the drive PCB near each potentiometer to measure the potentiometer value.

**Loop Tuning Switch Functions**

In general, the drive will not need to be further tuned beyond the default configuration. However, for applications requiring more precise tuning, DIP switches can be used to adjust the current and velocity loop tuning values. Some general rules of thumb to follow when tuning the drive are:

- A larger resistor value will increase the proportional gain, and therefore create a faster response time.
- A larger capacitor value will increase the integration time, and therefore create a slower response time.

Proper tuning will require careful observation of the loop response on a digital oscilloscope to find optimal DIP switch settings for the specific application.

**(Note: Drive cover must be removed to access SW2 and SW3)**

SW2 DIP switches 1-4 add additional parallel capacitance to the velocity loop integrator capacitor (see Block Diagram). The resulting velocity loop capacitance values are given in the table below along with the appropriate DIP switch settings. By default, all SW2 switches are OFF (shaded in the SW2 table below).

SW2																
Switch	Velocity Loop Integrator Capacitance Options (μF)															
	.047	.147	.267	.367	.517	.617	.737	.837	1.047	1.147	1.267	1.367	1.517	1.617	1.737	1.837
SW2-1	OFF	ON	OFF	ON	OFF	ON	OFF	ON	OFF	ON	OFF	ON	OFF	ON	OFF	ON
SW2-2	OFF	OFF	ON	ON	OFF	OFF	ON	ON	OFF	OFF	ON	ON	OFF	OFF	ON	ON
SW2-3	OFF	OFF	OFF	OFF	ON	ON	ON	ON	OFF	OFF	OFF	OFF	ON	ON	ON	ON
SW2-4	OFF	OFF	OFF	OFF	OFF	OFF	OFF	OFF	ON	ON	ON	ON	ON	ON	ON	ON

Note: The velocity loop integrator capacitor can be shorted entirely by setting SW1-3 to OFF.

SW3 DIP switches add additional resistance and capacitance to the current loop tuning circuitry. SW3 switches 1-5 add additional series resistance to the current loop gain resistor, and SW3 switches 6-10 add additional parallel capacitance to the current loop integrator capacitor (see Block Diagram). Capacitance and resistance values are given in the tables below along with the appropriate DIP switch settings.

SW3																
Switch	Current Loop Proportional Gain Resistance Options (kΩ)															
	10	20	30	40	50	60	70	80	90	100	110	120	130	140	150	160
SW3-1	ON	ON	OFF	ON	OFF	ON	OFF	ON	OFF	ON	OFF	ON	OFF	ON	OFF	ON
SW3-2	ON	ON	ON	OFF	OFF	ON	ON	OFF	OFF	ON	ON	OFF	OFF	ON	ON	OFF
SW3-3	ON	ON	ON	ON	ON	OFF	OFF	OFF	OFF	ON	ON	ON	ON	OFF	OFF	OFF
SW3-4	ON	ON	ON	ON	ON	ON	ON	ON	ON	OFF	OFF	OFF	OFF	OFF	OFF	OFF
SW3-5	ON	ON	ON	ON	ON	ON	ON	ON	ON	ON	ON	ON	ON	ON	ON	ON
Switch (continued)	170	180	190	200	210	220	230	240	250	260	270	280	290	300	310	320
SW3-1	ON	ON	OFF	ON	OFF	ON	OFF	ON	OFF	ON	OFF	ON	OFF	ON	OFF	ON
SW3-2	ON	ON	ON	OFF	OFF	ON	ON	OFF	OFF	ON	ON	OFF	OFF	ON	ON	OFF
SW3-3	ON	ON	ON	ON	ON	OFF	OFF	OFF	OFF	ON	ON	ON	ON	OFF	OFF	OFF
SW3-4	ON	ON	ON	ON	ON	ON	ON	ON	ON	OFF	OFF	OFF	OFF	OFF	OFF	OFF
SW3-5	OFF	OFF	OFF	OFF	OFF	OFF	OFF	OFF	OFF	OFF	OFF	OFF	OFF	OFF	OFF	OFF

SW3																	
Switch	Current Loop Integrator Capacitance Options (μF)																
	.0047	.0094	.0247	.0294	.0517	.0564	.0717	.0764	.0987	.1034	.1187	.1234	.1457	.1504	.1647	.1694	Short
SW3-6	OFF	ON	OFF	ON	OFF	ON	OFF	ON	OFF	ON	OFF	ON	OFF	ON	OFF	ON	ON
SW3-7	OFF	OFF	ON	ON	OFF	OFF	ON	ON	OFF	OFF	ON	ON	OFF	OFF	ON	ON	ON
SW3-8	OFF	OFF	OFF	OFF	ON	ON	ON	ON	OFF	OFF	OFF	OFF	ON	ON	ON	ON	ON
SW3-9	OFF	OFF	OFF	OFF	OFF	OFF	OFF	OFF	ON	ON	ON	ON	ON	ON	ON	ON	ON
SW3-10	OFF	OFF	OFF	OFF	OFF	OFF	OFF	OFF	OFF	OFF	OFF	OFF	OFF	OFF	OFF	OFF	ON

**MECHANICAL INFORMATION**

**P1 - Signal Connector**

Connector Information	16-pin, 2.54 mm spaced, friction lock header	
Mating Connector	Details	Molex: P/N 22-01-3167 (connector) and P/N 08-50-0114 (insert terminals)
	Included with Drive	Yes

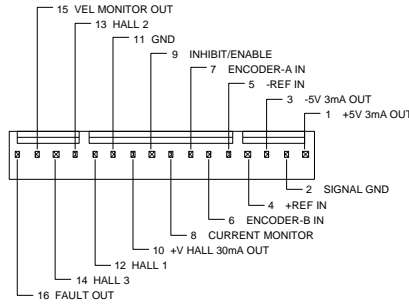

**P2 - Power Connector**

Connector Information	5-port, 5.08 mm spaced, quick-disconnect terminal	
Mating Connector	Details	Phoenix: P/N 1911994
	Included with Drive	Yes

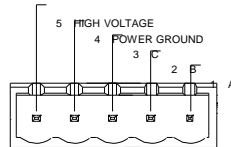

MIDWEST MOTION PRODUCTS

**MOUNTING DIMENSIONS**

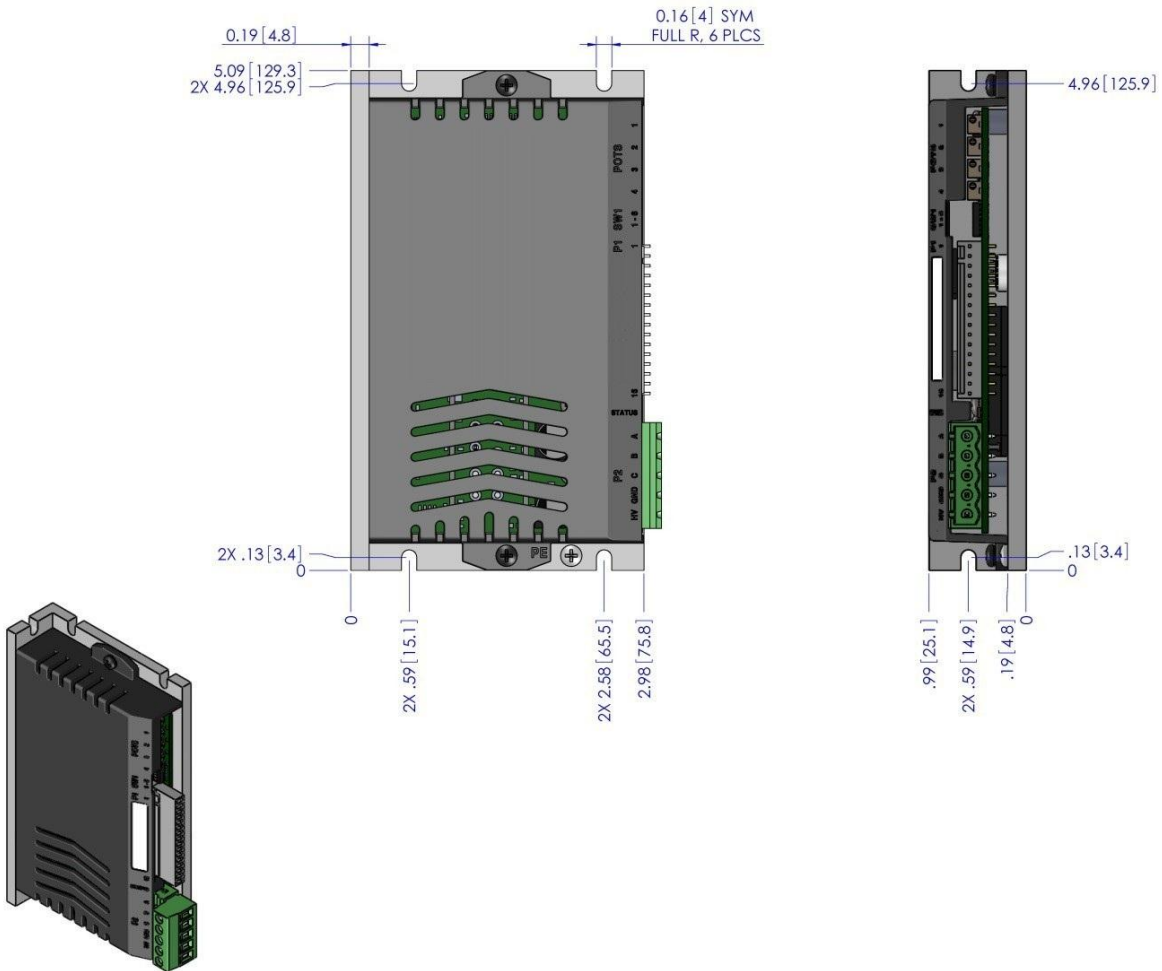

MIDWEST MOTION PRODUCTS