

Description

MMP SA-125200A servo amplifiers are designed to drive brushless DC motors at a high switching frequency. They are fully protected against over-voltage, over-current, over-heating, under-voltage and short-circuits. This model interfaces with digital controllers or can be used as a stand-alone drive and requires only a single unregulated DC power supply or battery. A single red/green LED and a single digital output indicate operating status. Loop gain, current limit, input gain, and offset can be adjusted using 14-turn potentiometers. The offset adjusting potentiometer can also be used as an on-board input signal for testing purposes. It will accept tachometer input, quadrature encoder inputs, or Hall sensor inputs for velocity control.

Power Range

Peak Current	200 A
Continuous Current	125 A
Supply Voltage	20 - 80 VDC

Features

- ▲ Four Quadrant Regenerative Operation
- ▲ Ramped Command Input Adjustment
- ▲ Drive Brushed or Brushless Motors
- ▲ Compact Size, High Power Density
- ▲ Selectable 120/60 Hall Commutation Phasing
- ▲ Offset Adjustment Potentiometer
- ▲ Ingress Protection Rating: IP65
- ▲ Selectable Inhibit/Enable Logic
- ▲ Adjustable Current Limits
- ▲ Multiple Modes of Operation

MODES OF OPERATION

- Current
- Voltage
- Duty Cycle (Open Loop)
- IR Compensation
- Velocity
- Hall Velocity

COMMAND SOURCE

- $\pm 10V$ Analog

FEEDBACK SUPPORTED

- Halls
- Incremental Encoder
- Tachometer (± 60 DC)

INPUTS/OUTPUTS

- Inhibit/Enable Input
- Current Monitor Output
- Velocity Monitor Output
- Fault Output

COMPLIANCES & AGENCY APPROVALS

- UL
- cUL
- RoHS
- CE Pending

BLOCK DIAGRAM

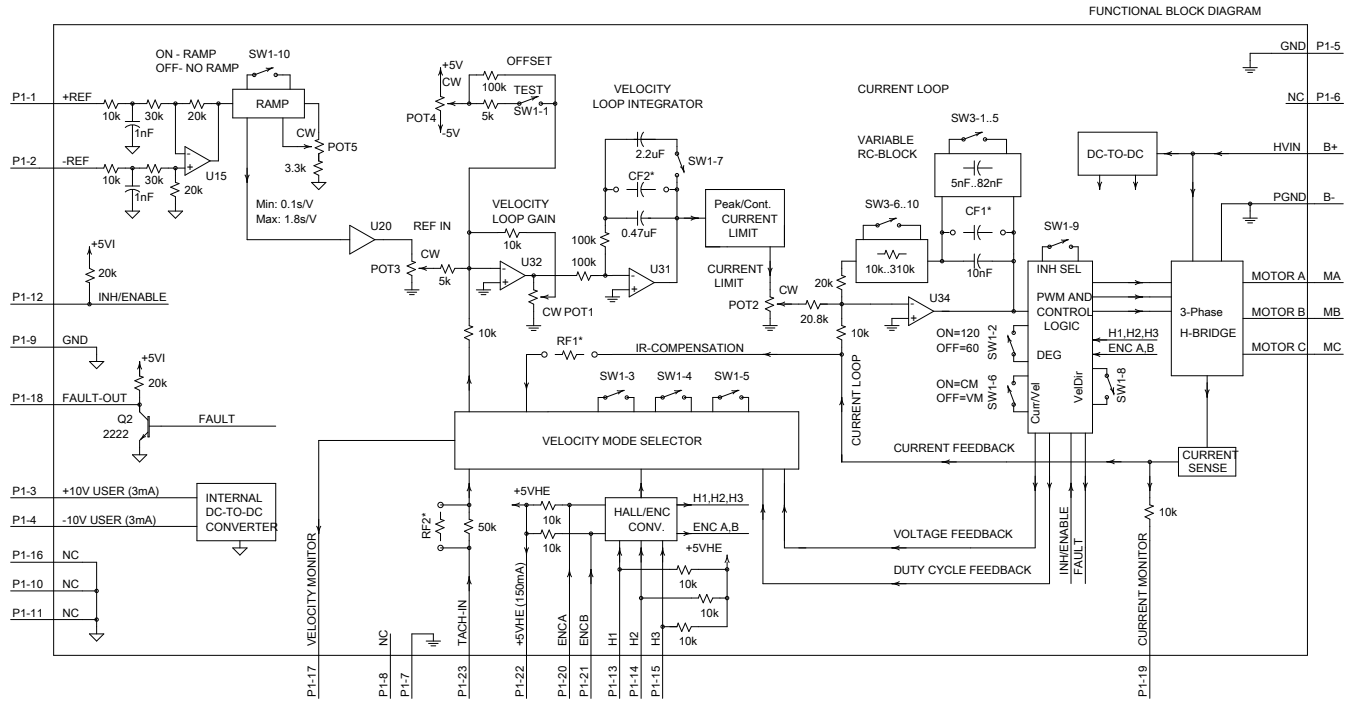

MODE SELECTION	SW1-3	SW1-4	SW1-5	SW1-6	SW1-7
CURRENT	N/A	N/A	N/A	ON	N/A
HALL VELOCITY	ON	ON	OFF	OFF	ON
ENCODER VELOCITY	OFF	ON	OFF	OFF	X
DUTY CYCLE	ON	OFF	OFF	OFF	X
VOLTAGE	OFF	OFF	OFF	OFF	X
TACHOMETER	N/A	N/A	ON	OFF	X

N/A - NOT APPLICABLE
 X - DEPENDENT ON APPLICATION

LED GREEN - NORMAL OPERATION, LED RED - FAULT
 RECOMMENDED SETTINGS FOR CURRENT MODE - POT1 FULLY CCW, POT3 FULLY CW
 DRIVES ARE SHIPPED IN CURRENT MODE WITH MAXIMUM CURRENT SETTINGS
 FOR OTHER SWITCH FUNCTIONS SEE SWITCH DESCRIPTION
 * OPTIONAL USER INSTALLED THROUGH HOLE COMPONENTS

Information on Approvals and Compliances



US and Canadian safety compliance with UL 508c, the industrial standard for power conversion electronics. UL registered under file number E140173. Note that machine components compliant with UL are considered UL registered as opposed to UL listed as would be the case for commercial products.



RoHS (Reduction of Hazardous Substances) is intended to prevent hazardous substances such as lead from being manufactured in electrical and electronic equipment.

SPECIFICATIONS

Power Specifications		
Description	Units	Value
DC Supply Voltage Range	VDC	20 - 80
DC Bus Over Voltage Limit	VDC	92
DC Bus Under Voltage Limit	VDC	16
Maximum Peak Output Current ¹	A	200
Maximum Continuous Output Current	A	125
Max. Continuous Output Power	W	9500
Max. Continuous Power Dissipation	W	500
Internal Bus Capacitance	µF	6000
Minimum Load Inductance (Line-To-Line) ²	µH	250
Switching Frequency	kHz	14.6
Maximum Output PWM Duty Cycle	%	100
Control Specifications		
Description	Units	Value
Command Sources	-	±10V Analog
Feedback Supported	-	Halls, Incremental Encoder, Tachometer (±60 VDC)
Commutation Methods	-	Trapezoidal
Modes of Operation	-	Current, Voltage, IR Compensation, Duty Cycle, Hall Velocity, Velocity, Duty Cycle (Open Loop)
Motors Supported	-	Single Phase (Brushed, Voice Coil, Inductive Load), Three Phase (Brushless)
Hardware Protection	-	Over Current, Over Temperature, Over Voltage, Short Circuit (Phase-Phase & Phase-Ground), Under Voltage
Mechanical Specifications		
Description	Units	Value
Agency Approvals	-	cUL, UL, RoHS, CE Pending
Size (H x W x D)	mm (in)	203.2 x 139.7 x 59.7 (8.0 x 5.5 x 2.4)
Size (H x W x D) with 23-pin mating connector installed	mm (in)	203.2 x 139.7 x 74.0 (8.0 x 5.5 x 2.9)
Weight	g (oz)	1638.60 (57.80)
Heatsink (Base) Temperature Range ³	°C (°F)	0 - 75 (32 - 167)
Storage Temperature Range	°C (°F)	-20 - 85 (-4 - 185)
Cooling System ³	-	Natural Convection
Form Factor	-	Vehicle Mount
IP Rating	-	65
I/O Connector	-	23-pin, AMPSEAL connector
MOTOR POWER Connector	-	3 Individual M6 threaded terminals
POWER Connector	-	2 Individual M6 threaded terminals

Notes

1. Maximum duration of peak current is ~5 seconds for zero-to-peak current command, and ~10 seconds for peak-to-peak current command.
2. Lower inductance is acceptable for bus voltages well below maximum. Use external inductance to meet requirements.
3. Additional cooling and/or heatsink is required to achieve rated performance. Thermal grease recommended between baseplate and external heatsink.

PIN FUNCTIONS

I/O - Signal Connector			
Pin	Name	Description / Notes	I/O
1	+REF IN	Differential Reference Input (± 10 V Operating Range, ± 15 V Maximum Input)	I
2	-REF IN		I
3	+10V 3mA OUT	± 10 V @ 3 mA low power supply for customer use. Short Circuit Protected. Reference ground common with signal ground.	O
4	-10V 3mA OUT		O
5	POWER GROUND	Power Ground	PGND
6	RESERVED	Reserved	-
7	POWER GROUND	Power Ground (Low current. 500 mA max)	PGND
8	RESERVED	Reserved	-
9	SIGNAL GROUND	Signal Ground	SGND
10	SIGNAL GROUND		SGND
11	SIGNAL GROUND		SGND
12	INHIBIT/ENABLE	This TTL level input signal turns off all power devices of the "H" bridge when pulled to Signal Ground with SW1-9=ON. If SW1-9=OFF, pulling this pin to Signal Ground will enable the drive.	I
13	HALL 1	Hall sensor inputs. Logic levels: maximum low level input is 1.5 VDC, minimum high level input is 3.5 VDC. Reference to Power Ground.	I
14	HALL 2		I
15	HALL 3		I
16	SIGNAL GROUND	Signal Ground	SGND
17	VELOCITY MONITOR	1V = 21.5 kHz Encoder Frequency; 1V = 100 Hz Hall Sensor Frequency. Reference to Power Ground.	O
18	FAULT OUT	This output activates during short circuit, over-voltage, under voltage, inhibit, over-temperature and power-on reset. A red LED on the drive also indicates a fault condition. Reference to Signal Ground. Can be used with an external voltage supply and LED for visual fault indication.	O
19	CURRENT MONITOR	Scaling factor = 27.4 A/V. This output represents the actual motor output current. Reference to Power Ground.	O
20	ENCODER A	Encoder Channel A. Reference to Power Ground.	I
21	ENCODER B	Encoder Channel B. Reference to Power Ground.	I
22	+5V OUT	+5V @ 150mA. For customer use. Reference to Power Ground.	O
23	TACH	Tachometer Input, 60k ohm input resistance, ± 60 V max. Reference to Power Ground.	I

MOTOR POWER - Power Connector			
Terminal	Name	Description / Notes	I/O
MA	MOTOR A	Motor Phase A	O
MB	MOTOR B	Motor Phase B	O
MC	MOTOR C	Motor Phase C	O

POWER - Power Connector			
Terminal	Name	Description / Notes	I/O
B-	POWER GROUND	Power Ground	PGND
B+	HIGH VOLTAGE	DC Power Input. Battery Power.	I

HARDWARE SETTINGS

Switch Functions

SW1			
Switch	Description	Setting	
		On	Off
1	Test / Offset controls the sensitivity of the "offset" pot. This is used as an on-board reference signal in test mode.	Test	Offset
2	120/60 degree commutation phasing.	120 degree phasing	60 degree phasing
3	Mode Select. Refer to Mode Selection Table	Duty-Cycle / Hall	IR Comp / Encoder
4	Mode Select. Refer to Mode Selection Table	Hall / Encoder	Duty-Cycle
5	Mode Select. Refer to Mode Selection Table	Tach Mode	Other Modes
6	Mode Select. Refer to Mode Selection Table	Current Mode	Velocity Modes
7	Velocity Integrator Capacitor	More Capacitance (ON for Hall Velocity Mode)	Less Capacitance
8	Velocity Feedback Polarity (for Hall or Encoder Velocity Mode)	One Direction	Opposite Direction
9	Inhibit / Enable Logic Select	Ground Inhibit pin to Inhibit	Ground Inhibit enable motor outputs
10	Ramp Enable	Enable Command Ramping	No Command Ramping

	SW1-1	SW1-2	SW1-3	SW1-4	SW1-5	SW1-6	SW1-7	SW1-8	SW1-9	SW1-10
CURRENT	X	X	X	X	OFF	ON	X	X	X	X
DUTY CYCLE	X	X	ON	OFF	OFF	OFF	X	X	X	X
VOLTAGE	X	X	OFF	OFF	OFF	OFF	X	X	X	X
IR COMPENSATION*	X	X	OFF	OFF	OFF	OFF	X	X	X	X
HALL VELOCITY	X	X	ON	ON	OFF	OFF	ON	X	X	X
ENCODER VELOCITY	X	X	OFF	ON	OFF	OFF	X	X	X	X
TACHOMETER	X	X	X	X	ON	OFF	X	X	X	X

X = does not affect mode

* IR Comp Mode requires the addition of an IR Comp resistor RF1 on the PCB.

Current Loop Tuning Values

SW3 DIP switches add additional resistance and capacitance to the current loop tuning circuitry. SW3 switches 1-5 add additional parallel capacitance to the current loop integrator capacitor, and SW3 switches 6-10 add additional series resistance to the current loop gain resistor (see Block Diagram). Capacitance and resistance values are given in the tables below along with the appropriate DIP switch settings.

SW3																	
Switch	Additional Current Loop Integrator Capacitance (µF)																
	SHORT	.082	.077	.072	.067	.062	.057	.052	.047	.035	.030	.025	.020	.015	.010	.005	OPEN
1	ON	ON	OFF	ON	OFF	ON	OFF	ON	OFF	ON	OFF	ON	OFF	ON	OFF	ON	OFF
2	ON	ON	ON	OFF	OFF	ON	ON	OFF	OFF	ON	ON	OFF	OFF	ON	ON	OFF	OFF
3	ON	ON	ON	ON	ON	OFF	OFF	OFF	OFF	ON	ON	ON	ON	OFF	OFF	OFF	OFF
4	ON	ON	ON	ON	ON	ON	ON	ON	ON	OFF	OFF	OFF	OFF	OFF	OFF	OFF	OFF
5	ON	OFF	OFF	OFF	OFF	OFF	OFF	OFF	OFF	OFF	OFF	OFF	OFF	OFF	OFF	OFF	OFF

SW3																
Switch	Additional Current Loop Gain Resistance (kΩ)															
	0	10	20	30	40	50	60	70	80	90	100	110	120	130	140	150
6	ON	OFF	ON	OFF	ON	OFF	ON	OFF	ON	OFF	ON	OFF	ON	OFF	ON	OFF
7	ON	ON	OFF	OFF	ON	ON	OFF	OFF	ON	ON	OFF	OFF	ON	ON	OFF	OFF
8	ON	ON	ON	ON	OFF	OFF	OFF	OFF	ON	ON	ON	ON	OFF	OFF	OFF	OFF
9	ON	ON	ON	ON	ON	ON	ON	ON	OFF	OFF	OFF	OFF	OFF	OFF	OFF	OFF
10	ON	ON	ON	ON	ON	ON	ON	ON	ON	ON	ON	ON	ON	ON	ON	ON
Switch (continued)	160	170	180	190	200	210	220	230	240	250	260	270	280	290	300	310
6	ON	OFF	ON	OFF	ON	OFF	ON	OFF	ON	OFF	ON	OFF	ON	OFF	ON	OFF
7	ON	ON	OFF	OFF	ON	ON	OFF	OFF	ON	ON	OFF	OFF	ON	ON	OFF	OFF
8	ON	ON	ON	ON	OFF	OFF	OFF	OFF	ON	ON	ON	ON	OFF	OFF	OFF	OFF
9	ON	ON	ON	ON	ON	ON	ON	ON	OFF	OFF	OFF	OFF	OFF	OFF	OFF	OFF
10	OFF	OFF	OFF	OFF	OFF	OFF	OFF	OFF	OFF	OFF	OFF	OFF	OFF	OFF	OFF	OFF

Potentiometer Functions

Potentiometer	Description	Turning CW
Pot 1	Loop gain adjustment in duty cycle and velocity modes. Turn this pot fully CCW in current mode.	Increases loop gain
Pot 2	Current limit. This potentiometer adjusts both the continuous and peak current limit while maintaining the continuous to peak ratio (~63%).	Increases current limit
Pot 3	Reference in gain. This potentiometer adjusts the ratio between input signal and output variables (voltage, current, and velocity).	Increases reference input gain
Pot 4	Test/Offset. Used to adjust any imbalance in the input signal or in the drive. When SW1-1 (DIP switch) is ON, the sensitivity of this pot is greatly increased allowing it to be used as an on-board signal source for testing purposes.	Zero speed setting is at the midpoint of this 14-turn pot.
Pot 5	Ramp Time. Sets the ramp time for the command input signal.	Decreases ramp time (faster response time)

Note: Potentiometers are approximately linear and have 12 active turns plus 1 inactive turn on each end.

Ramping (Pot 5):

The built-in ramp circuit allows the command input to be ramped linearly. This feature is activated by setting SW1-10 = ON. The ramp time can be set for up to 20 seconds in reaching the max command by adjusting Pot 5 fully counter-clockwise. Ramping rates are linear with respect to time and apply to both directions of motion. For example, if the single-ended command input is only 2.5 Volts, the time to ramp to this voltage would be half the time to ramp to 5 Volts.

Current Limit Adjustments:

These amplifiers feature separate peak and continuous current limits. The current limit adjustment Pot 2 adjusts both peak and continuous current limit at the same time. Pot 2 has 12 active turns and one inactive turn on each end and is approximately linear. Thus, to adjust the current limit turn the potentiometer counter-clockwise to zero, then turn clockwise to the appropriate value.

Through-hole Components[†]

Location	Description
CF2*	Velocity Loop Integrator. Through-hole capacitor that can be added for more precise velocity loop tuning. See section below on Tuning with Through-hole components for more details.
CF1*	Current Loop Integrator. Through-hole capacitor that can be added for more precise current loop tuning. See section below on Tuning with Through-hole components for more details.
RF2*	Tachometer Gain Scaling. Through-hole resistor that can be added to change the gain of the tachometer input. See section below on Tachometer Gain for more details.
RF1*	IR Compensation Scaling. Through-hole resistor that can be added to configure the amplifier for IR Compensation mode. See section below on IR Compensation Notes for more details.

Tuning With Through-hole Components

In general, the drive will not need to be further tuned with through-hole components. However, for applications requiring more precise tuning than what is offered by the potentiometers and DIP switches, the drive can be manually modified with through-hole capacitors as denoted in the above table. By default, the through-hole locations are not populated when the drive is shipped. Before attempting to add through-hole components to the board, consult the section on loop tuning in the installation notes on the manufacturer's website. A general rule of thumb to follow when adding through-hole components is:

- A larger capacitor value will increase the integration time, and therefore create a slower response time.

Proper tuning using the through-hole components will require careful observation of the loop response on a digital oscilloscope to find the optimal through-hole component values for the specific application.

Tachometer Gain

Some applications may require an increase in the gain of the tachometer input signal. This occurrence will be most common in designs where the tachometer input has a low voltage to RPM scaling ratio. The drive offers a through-hole location listed in the above table where a resistor can be added to increase the tachometer gain. Use the drive's block diagram to determine an appropriate resistor value.

IR Compensation

For applications that will use IR Compensation mode, a resistor can be added to the location named in the table above. The combination of the added resistor and correct DIP switch settings will configure the amplifier for IR Compensation mode. While in IR Compensation mode, the amplifier will adjust the duty cycle to compensate for changes in the output current. Consult the amplifier's functional block diagram and the manufacturer's website for more information.

[†]NOTE: DAMAGE DONE TO THE DRIVE WHILE PERFORMING THESE MODIFICATIONS WILL VOID THE WARRANTY.

MECHANICAL INFORMATION

I/O - Signal Connector

Connector Information		23-pin, AMPSEAL connector
Mating Connector	Details	TE Connectivity: Housing P/N 770680-1; Socket Contacts P/N 770854-3 (loose); Seal Plug P/N 770678-1; Crimp Tool P/N 58529-1
	Included with Drive	No

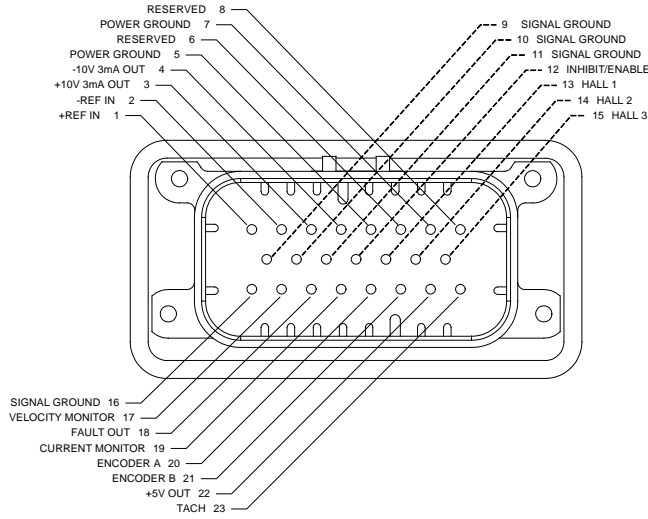

MOTOR POWER - Power Connector

Connector Information		Three individual M6 threaded terminal
Mating Connector	Details	M6 screw or bolt with washer
	Included with Drive	Yes

POWER - Power Connector

Connector Information		Two individual M6 threaded terminal
Mating Connector	Details	M6 screw or bolt with washer
	Included with Drive	Yes

WIRING DIAGRAM

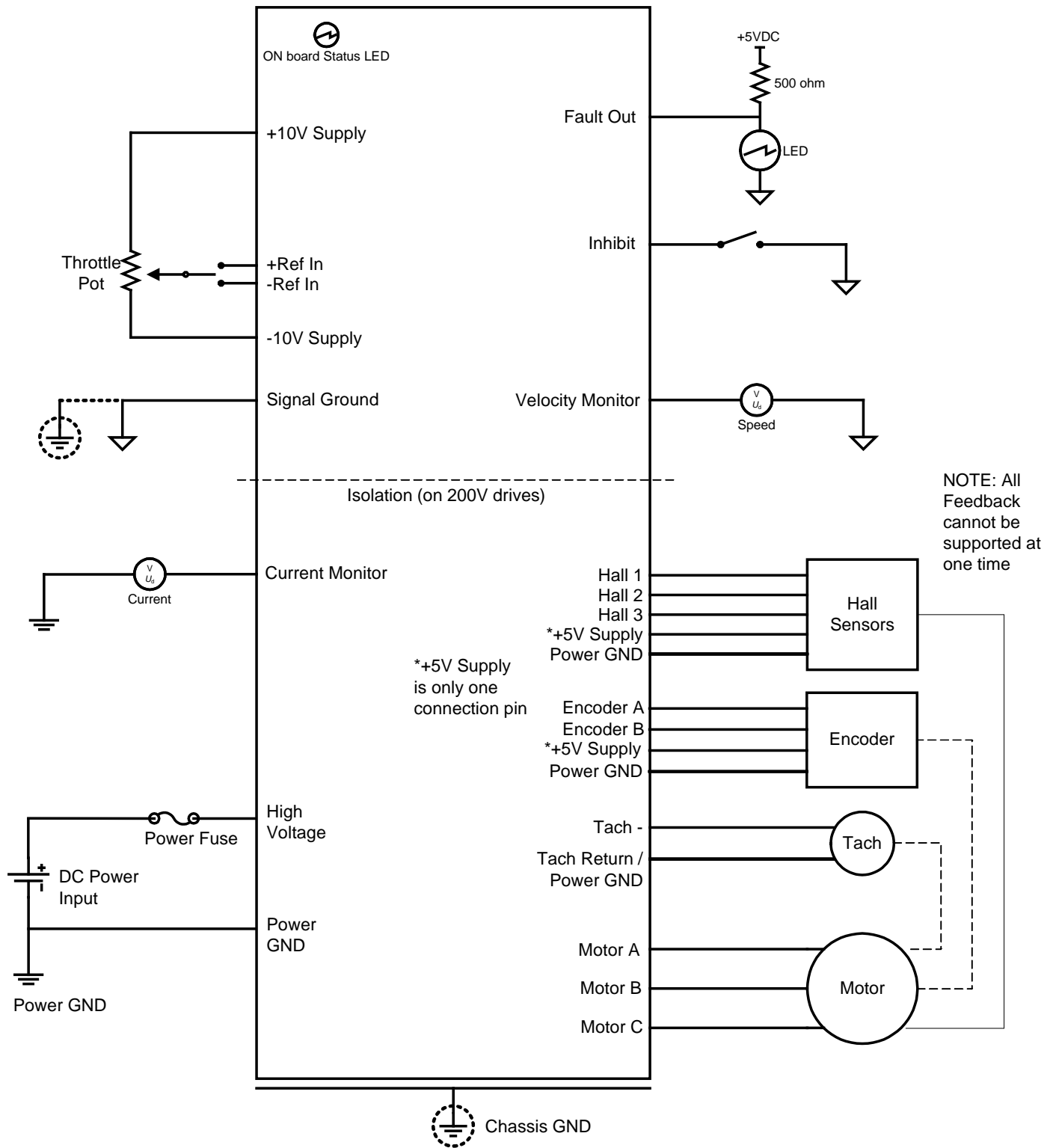

MOUNTING DIMENSIONS

